

GLASS WALL

Operable Partition

Operable | Semi Automatic | Double Glass | STC 48 dB

Why SSJ Partition?

Your Vision, Our Precision – Custom Solutions Crafted for You.



SSJ Partition Wall Co. Ltd

G103, No. 3 Dalisha Rd, Zhucun, Tianhe District, Guangzhou China.
T: 86 191 2866 3436 E: suzubin@ssjpartition.com

All rights reserved. No part of this publication may be reproduced, stored in any retrieval system, or transmitted in any form or by any means, photocopying, or otherwise without the publisher's prior written permission.





SSJ Glass operable partitions

SSJ Partition Co. Ltd is a modern enterprise focusing on high-end partition walls design, research and development, production, installation and after-sales service. We are committed to providing customers with high-quality, personalized, environmentally friendly and energy-saving partition solutions to help create efficient, comfortable and beautiful flexible spaces.

Double glazed operable partitions combining the transparent aesthetic as well as excellent acoustic performance. By bringing daylight into every partitioned room, transparent glass creates a bright and stylish environment to your space and it is also an eco-friendly solution to save lighting power and cost. With the double glazed panel system, acoustic performance is further enhanced to up to STC 48. Characterized with its welded heavy-duty galvanized steel frame, it is highly rigid and durable. A coloured powdercoat finish on the aluminum and glass border can be upgraded to cater different design requirements. When protection against light and glare is required, the system can be enhanced through integration of venetian blinds.

Features



Semi Automatic 01

One-touch control for effortless mechanical seal adjustment



Integrated Hinge 02

Enhanced stability with silent closure



High-end Lock 03

Sleek customizable designs & colors



T intersection 04

The 90° connection with superb craftsmanship is light-tight and ensures the best sound insulation effect.

Product Overview

Specification Overview	Acoustic Ratings	Max Height (m)	Max Opening Widths (m)	Panel Configuration	Lever Closure	Track / Stacking Options
AL5000G	STC 46 or 48	3.6	Unlimited	Omni	Optional	Omni
Acoustic Seals / Sweeps	Handle & Floor Locks	Pass Doors / Pivot Doors / Full-height Door	Standard Frame Finishes	Glass Types		Hanging Weights
With top and bottom mechanical seals and sweep: 25mm top and bottom clearance	Optional - master key prep, core cylinder key, thumb turn & pin	Optional	Clear Anodized	(STC42) 10mm Tempered Standard	(STC48) 11mm Tempered Standard 11mm Laminated Standard	(STC42) 62.1 kg/m ² (STC48) 67.1 kg/m ²

Glass Options

Glass Options	Clear Tempered	Tempered Low Iron	Clear laminated	Switchable Privacy Glass
Description	Standard Clarity	Complete Visual Clarity	Laminate for super sound management	Available for 5000G Series

Type of Panel Door

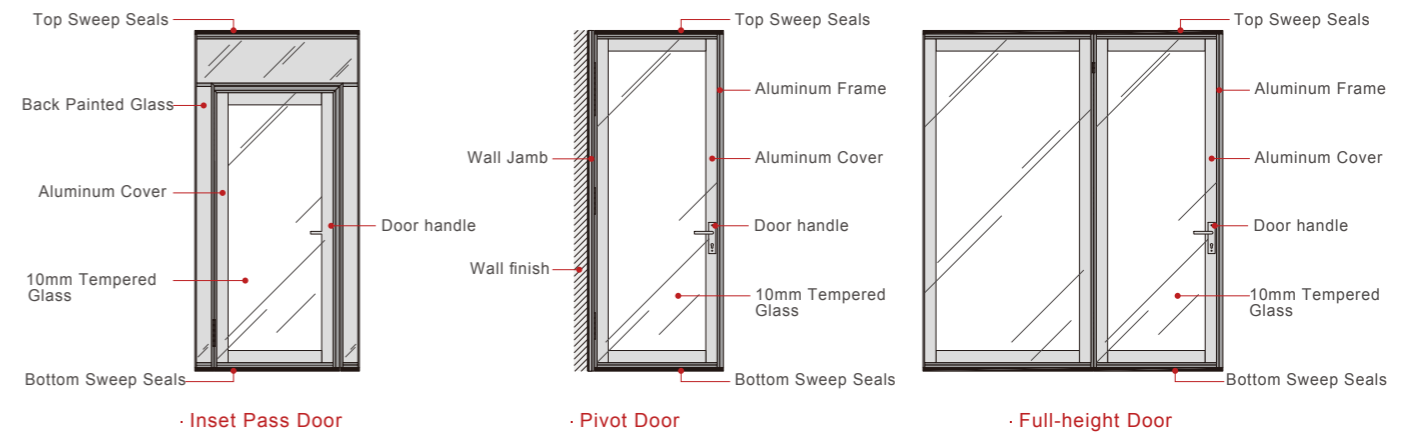

Specifications

Vertical section

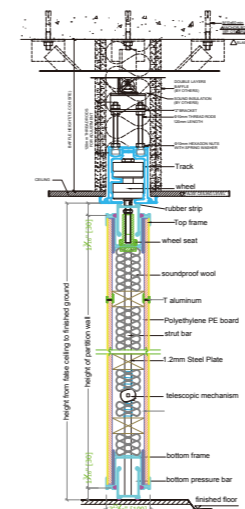

Horizontal section

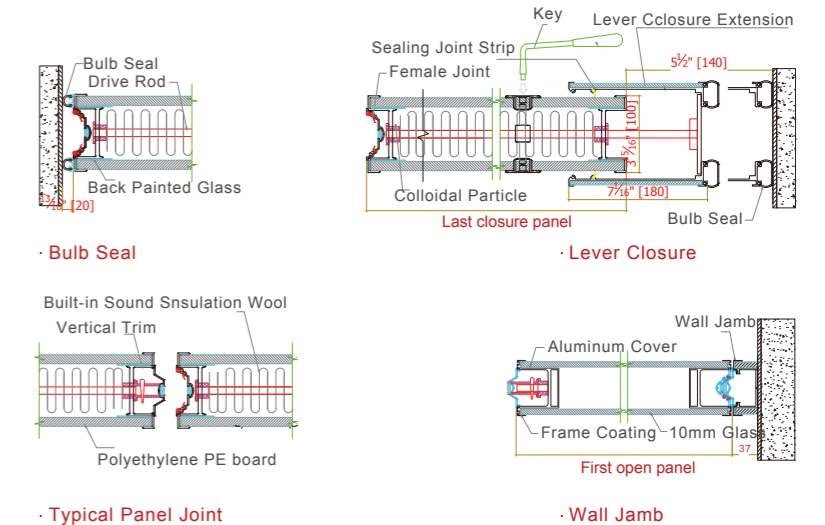

Aluminum Track Systems

A high quality track system ensures that SSJ partitions will operate smoothly for years to come and assist in the quick set-up and storage of panels. All SSJ tracks have been rigorously tested for a minimum of 150 miles (241km), approx. 20 years of usage cycle time. Job requirements vary, which is why SSJ offers a wide selection of tracks to meet your operating requirements.

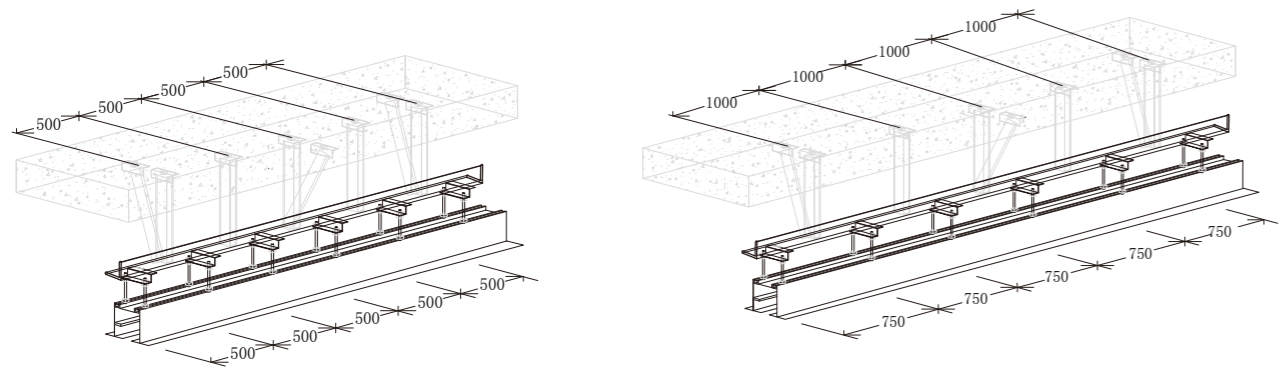

STACKING AREA

OPERATING AREA

TYPE 65

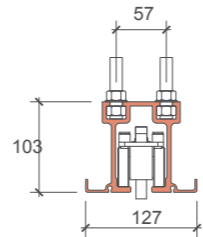

Weights up to 1200lbs (545kg) per panel

TYPE 80

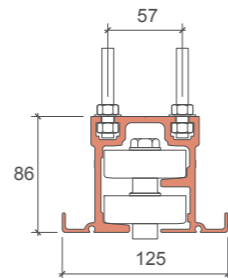
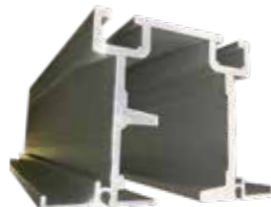

Weights up to 1000lbs (455kg) per panel

Omni-Directional Panels

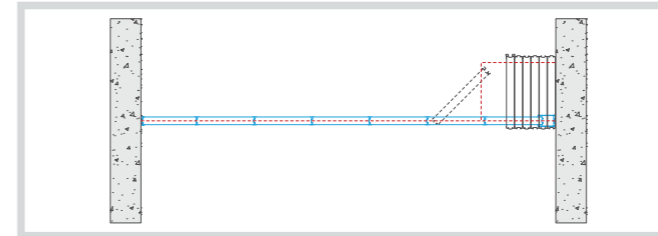

Omni-directional panels provide the ultimate flexibility to your operations because each individual panel can easily turn around corners and move to alternate locations or remote storage. Therefore, many different storage layouts can be created to fit your floor design and layout.

Storage Layout Options

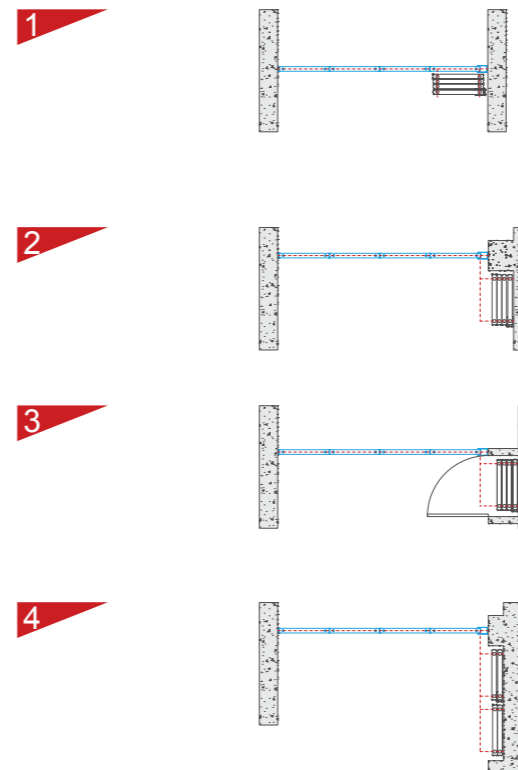

Customized

For upgraded glass options (e.g., clear tempered, frosted, switchable, or blinds-integrated glass), contact our team for customized solutions.

Paired Panels

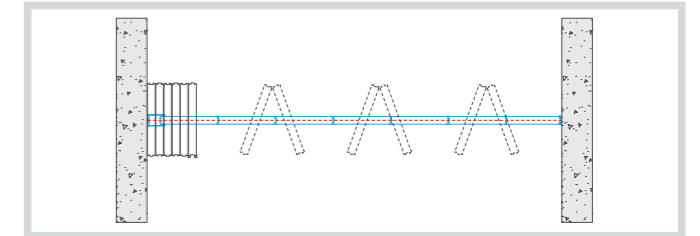

When remote storage is not required, the center-hung panels hinged in groups of two or three, are the ideal solution for quicker and easier set up, than omni-direction panels. Optional hinging is available to accommodate moldings or other decorations. Acoustical ratings are the same as omni-direction Panels.

Storage Layout Options

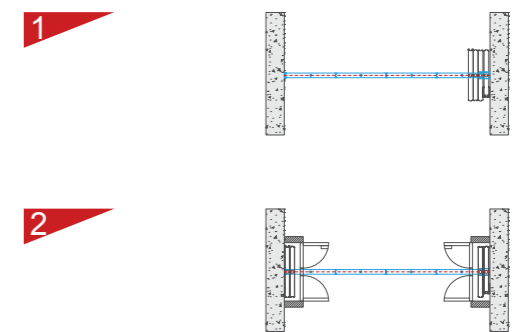

Warranty

- The partition system purchased and installed by the manufacturer's authorized agents shall be entitled to a warranty of 2-year against defects in material and workmanship.
- The aluminum frame shall be entitled to a 5-year warranty for free.